

MOTOR SPECIFICATION SHEET

MODEL : SCF-QRV 1/3HP 4P

USED FOR : STANDARD

DESCRIPTION	DETAIL				
PHASE	1				
TYPE	CAPACITOR START				
MODEL NAME	SCF-QRV				
RATED OUTPUT, HP (kW)	1/3 (0.25)				
POLE	4				
CODE	MEATH CODE : 1M001C-400030QVEU0				
OUTLINE DRAWING NO.	ONM74O059-B				
RATED VOLTAGE (V)	220	230	220		
RATED FREQUENCY (Hz)	50	50	60		
RATED CURRENT (A)	3.1	3.2	2.8		
RATED SPEED (min ⁻¹)	1450	1450	1740		
RATED EFFICIENCY (%)	64.9	63.5	69.6		
THERMAL CLASS	155(F)				
RATING	S1 (CONTINUOUS)				
ENCLOSURE CONSTRUCTION	TOTALLY ENCLOSED FAN COOLED				
DEGREES OF PROTECTION	IP55				
METHOD OF COOLING	IC411				
FRAME NO.	B71				
WEIGHT (kg)	9.8				
STANDARD	JEC-2137-2000				
EFFICIENCY RULE	IEC 60034-30-1				
INSTALLATION	FLANGE MOUNTED (VERTICAL)				
ROTATION	CCW (VIEWED FROM SHAFT END)				
BEARING	LOAD SIDE : 6202ZZ OPPOSITE SIDE : 6201ZZ				
BEARING GREASE	UREA GREASE				
NOISE (db.A)	63				
VIBRATION	V20				
CIRCUMSTANCE CONDITION	AMBIENT TEMPERATURE : -20 ~ +40°C AMBIENT HUMIDITY : 95%RH OR LESS ABOVE SEA LEVEL : 1000m OR LESS ENVIRONMENT : NO BURSTING/EROSIVE GAS OR VAPOR				
COLOR	MUNSELL N1.5 (BLACK)				
TERMINAL BOX	NO. OF LEAD WIRES : 2 SOURCE CONNECTION : TERMINAL BLOCK				
INSULATION RESISTANCE	BY DC 500V MEGGER - ≥100MΩ				
DIELECTRIC TEST	AC 50Hz 1500V - 1min. (Based on rated voltage 220V)				
SHAFT SWING	≤0.03mm				
MATERIAL	FRAME : STEEL PLATE BRACKET LOAD SIDE : CAST IRON (FLANGE) OPPOSITE SIDE : STEEL PLATE SHAFT : CARBON STEEL STATOR CORE : ELECTRICAL STEEL WIRE : ENAMELLED COPPER MAGNET WIRE INSULATOR : POLYESTER FILM SATURATED WITH RESIN VARNISH : EPOXY DENATURALIZATION POLYESTER ROTOR CORE : ELECTRICAL STEEL CONDUCTOR : ALUMINIUM TERMINAL BOX : STEEL PLATE PAINTING : POLYURETHANE RESIN				
PRODUCTION COUNTRY	THAILAND				

Specifications subject to change without notice.

SPECIFICATION SHEET NO.

SS-M-7222-B

MODEL SCF-QRV SINGLE PHASE INDUCTION MOTOR OUTLINE DRAWING

CAPACITOR START TYPE
 TOTALLY ENCLOSED FAN COOLED
 DEGREE OF PROTECTION IP55
 DUST & WATER JET PROOF
 FRAME NO. B71

CUSTOMER _____
 USER _____
 FOR _____
 CUSTOMER'S _____
 ORDER NO. _____
 QUANTITY _____
 MFG. _____
 ORDER NO. _____

STARTING CAPACITOR	80 μ F 250VAC
--------------------	-------------------

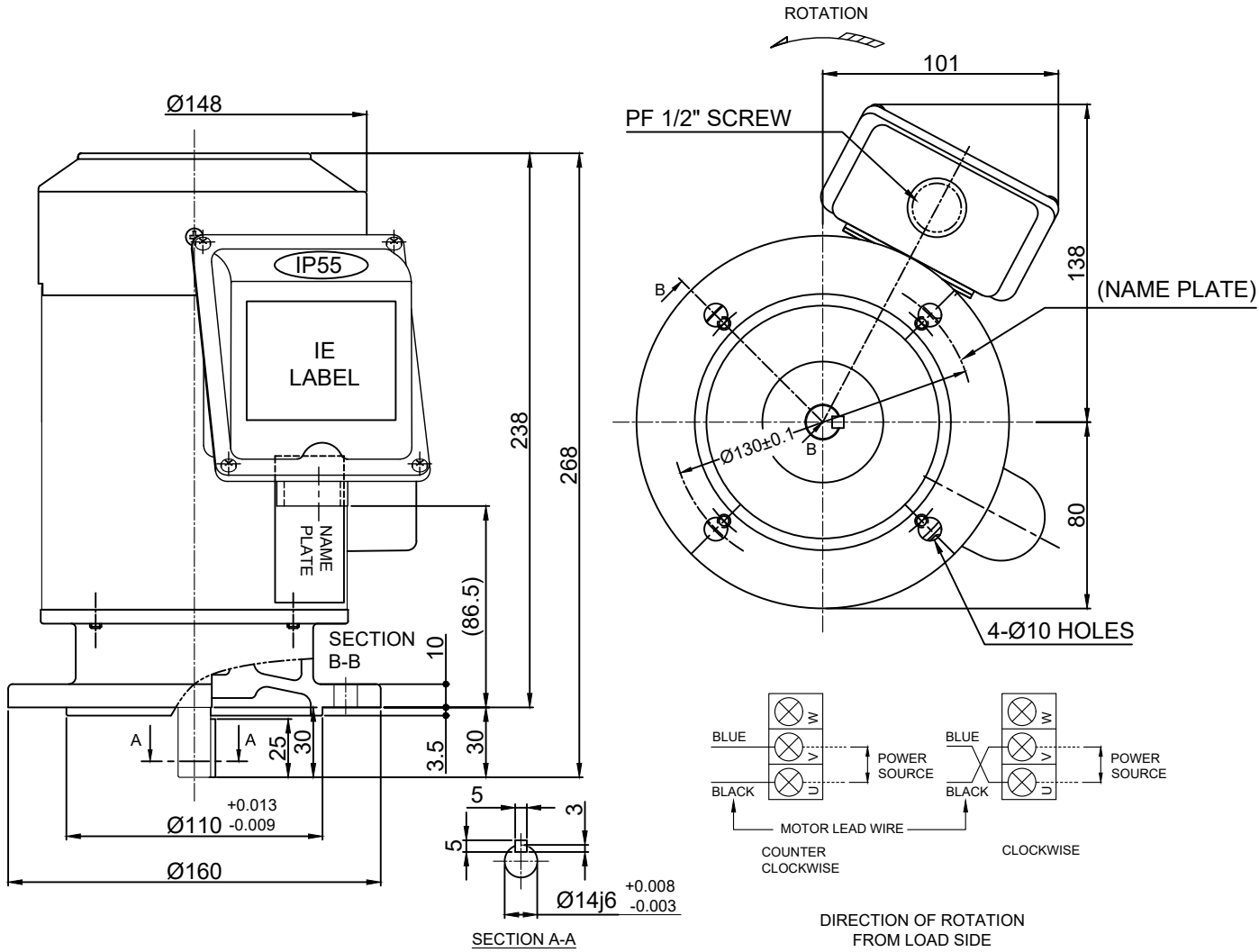

FRAME SIZE	RATING	TH. CLASS	AMB. TEMP.	BEARINGS		COLOR	DIRECTION OF ROTATION	NO. OF LEAD WIRES
				LOAD SIDE	OPP. SIDE			
B71	S1	155(F)	40°C	6202ZZ	6201ZZ	BLACK (MUNSELL N1.5)	CCW	2 WITH TERMINAL BOARD

OUTPUT		POLE	Hz	VOLT	AMP	RPM	IE CODE - RATED EFF.	REMARK
HP	kW							
1/3	0.25	4	50	220/230	3.1/3.2	1450/1450	IE1-64.9% / IE1-63.5%	
			60	220	2.8	1740	IE1-69.6%	

MITSUBISHI ELECTRIC AUTOMATION (THAILAND) CO.,LTD

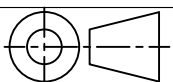

DIMENSION IN mm.

SCALE : NTS

OUTLINE DRAWING NO.

0 N M 7 4 0 0 5 9 B

REV.